

POWER RELAY

2 POLE—5 A (MEDIUM LOAD CONTROL)

VB SERIES

■ FEATURES

- UL, CSA, VDE, SEV, SEMKO, FIMKO, IMQ recognized TV-3 rated
- Working class: C
- UL class B (130°C) insulation
- Type of service: continuous duty
- Heavy duty miniature slim type power relay
- High isolation in small package
 - Insulation distance: 8 mm
 - Dielectric strength: 5,000 VAC (between coil and contacts)
 - Surge strength: 10,000 V
- Standard and high sensitivity types available
- Flux free type and plastic sealed type available

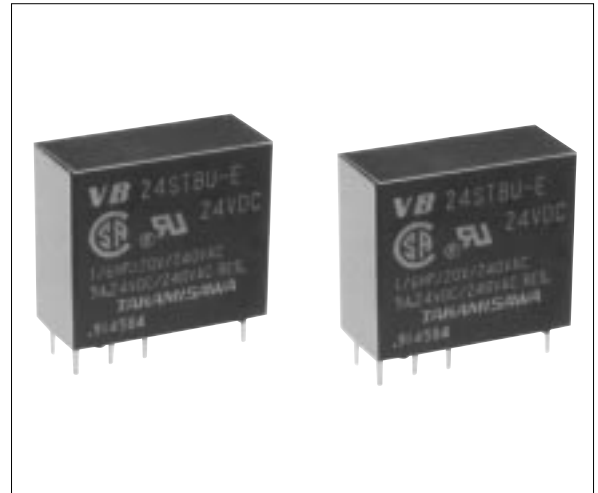

■ ORDERING INFORMATION

[Example] $\frac{VB}{(a)}$ - $\frac{12}{(*)}$ $\frac{S}{(b)}$ $\frac{M}{(c)}$ $\frac{B}{(d)}$ $\frac{U}{(e)}$ - $\frac{5}{(*)}$ $\frac{5}{(g)}$

(a)	Series Name	VB: VB Series
(b)	Nominal Voltage	Refer to the COIL DATA CHART
(c)	Coil Type	Nil : Standard type S : High sensitive type (non TV-rating)
(d)	Contact Arrangement	M : 2 form A (DPST-NO) T : 2 form C (DPDT)
(e)	Enclosure	B : Flux free type C : Plastic sealed type (with tape) K : Plastic sealed type
(f)	Standard	Nil : TV-rating U : General (non TV-rating)
(g)	Contact Material	Nil : Silver cadmium oxide (TV-3 rating) 5 : Silver cadmium oxide (non TV-rating) Nil : Gold overlay silver-nickel (non TV-rating) E : Silver-nickel (non TV-rating)

Actual marking omits the hyphen (-) of (*)

■ SAFETY STANDARD AND FILE NUMBERS

UL508, 873 (File No. E56140, E108658)

C 22.2 No. 1, No. 14 (File No. LR35579)

VDE0435, 0630, 0631, 0700, 0860 (File No. 11039-4940-1009)

Please note that UL/CSA ratings may differ from the standard ratings. Please request when the approval markings are required on the cover and/or when a relay recognized by VDE, SEV, SEMKO, FIMKO, IMQ is required.

	Type	Nominal voltage	Contact rating
TV-Rating	VB-() M	3 to 100 VDC	TV-3 120 VAC 1/6HP 120 VAC/240 VAC 5 A 24 VDC/240 VAC resistive 1.9A 250VAC inductive (PF=0.4) Pilot duty C 150
Standard	VB-() () U-() VB-() S () U-()	3 to 100 VDC	1/6HP 120 VAC/240 VAC 5 A 24 VDC/240 VAC resistive 1.9A 250VAC inductive (PF=0.4) Pilot duty C 150

VB SERIES

■ SPECIFICATIONS

Item		TV-3 Rating VB-() M	Standard Type	
			VB-() U-5	VB-() U VB-()-E
Contact	Arrangement	2 form A (DPST-NO)	2 form A (DPST-NO) or 2 form C (DPDT)	
	Material	Silver-cadmium oxide	Gold overlay silver-nickel (non gold overlay only VB-E)	
	Style	Single		
	Resistance (initial) (at 1 A 6 VDC)	Maximum 200 mΩ	Maximum 100 mΩ	
	Rating (resistive)	5 A 240 VAC/24 VDC		
	Maximum Carrying Current	7 A		
	Maximum Switching Power	1,200 VA, 120 W		
	Maximum Switching Voltage	380 VAC, 150 VDC		
	Maximum Switching Current	5 A		
	Minimum Switching Load *1	100 mA 5 VDC (VB-M, 5, E) 10 mA 5 VDC (VB-)		
	Maximum Inrush Current	51 A 120 VAC (at lamp load)	—	
Coil	Nominal Power (at 20°C)	Standard type: 0.70 to 0.75 W, high sensitivity type: 0.53 W		
	Operate Power (at 20°C)	Standard type: 0.35 to 0.37 W, high sensitivity type: 0.26 W		
	Operating Temperature	Standard type: -40°C to +65°C, high sensitivity type: -40°C to +75°C (no frost)		
Time Value	Operate (at nominal voltage)	Maximum 15 ms		
	Release (at nominal voltage)	Maximum 10 ms		
Insulation	Resistance (at 500 VDC)	Minimum 1,000 MΩ		
	Dielectric Strength	between open contacts	1,000 VAC 1 minute (3000 VAC between adjacent contacts)	
		between coil and contacts*2	5,000 VAC 1 minute	
Surge Strength*3	10,000 V at(1.2 × 50 μs)			
Life	Mechanical	2 × 10 ⁷ operations minimum		
	Electrical	1 × 10 ⁵ operations minimum at rated load		
		5 × 10 ⁴ operations minimum at motor load (1/8HP 120 VAC)	3 × 10 ⁴ operations minimum at motor load (1/8HP 120 VAC)	
		5 × 10 ⁴ operations minimum at lamp load	—	
Other	Vibration Resistance	Misoperation	10 to 55 Hz (double amplitude of 1.5 mm)	
		Endurance	10 to 55 Hz (double amplitude of 1.5 mm)	
	Shock Resistance	Misoperation	100 m/s ² (11 ± 1 ms)	
		Endurance	1,000 m/s ² (6 ± 1 ms)	
	Weight	Approximately 17 g		

*1 Minimum switching loads mentioned above are reference values. Please perform the confirmation test with the actual load before production since reference values may vary according to switching frequencies, environmental conditions and expected reliability levels.

*2 IMQ 

*3 IMQ 

VB SERIES

COIL DATA CHART

MODEL		Nominal voltage	Coil resistance (10%)	Must operate voltage	Must release voltage	Nominal power	
TV-3 Rating	Standard						
Standard Type	VB- 3M ()	VB- 3 () () U-()	3 V DC	12.5 Ω	2.1 VDC	0.3 VDC	0.72 W
	VB- 5M ()	VB- 5 () () U-()	5 V DC	36 Ω	3.5 VDC	0.5 VDC	0.70 W
	VB- 6M ()	VB- 6 () () U-()	6 V DC	50 Ω	4.2 VDC	0.6 VDC	0.72 W
	VB- 9M ()	VB- 9 () () U-()	9 V DC	115 Ω	6.3 VDC	0.9 VDC	0.70 W
	VB- 12M ()	VB- 12 () () U-()	12 V DC	200 Ω	8.4 VDC	1.2 VDC	0.72 W
	VB- 14M ()	VB- 14 () () U-()	14 V DC	280 Ω	9.8 VDC	1.4 VDC	0.70 W
	VB- 18M ()	VB- 18 () () U-()	18 V DC	460 Ω	12.6 VDC	1.8 VDC	0.70 W
	VB- 24M ()	VB- 24 () () U-()	24 V DC	820 Ω	16.8 VDC	2.4 VDC	0.70 W
	VB- 36M ()	VB- 36 () () U-()	36 V DC	1,850 Ω	25.2 VDC	3.6 VDC	0.70 W
	VB- 48M ()	VB- 48 () () U-()	48 V DC	3,300 Ω	33.6 VDC	4.8 VDC	0.70 W
	VB- 60M ()	VB- 60 () () U-()	60 V DC	5,100 Ω	42.0 VDC	6.0 VDC	0.70 W
	VB-100M ()	VB-100 () () U-()	100 V DC	13,400 Ω	70.0 VDC	10.0 VDC	0.75 W
High Sensitivity Type	VB- 3S () () U-()	3 V DC	17 Ω	2.1 VDC	0.3 VDC	0.53 W	
	VB- 5S () () U-()	5 V DC	47 Ω	3.5 VDC	0.5 VDC	0.53 W	
	VB- 6S () () U-()	6 V DC	68 Ω	4.2 VDC	0.6 VDC	0.53 W	
	VB- 9S () () U-()	9 V DC	155 Ω	6.3 VDC	0.9 VDC	0.53 W	
	VB-12S () () U-()	12 V DC	270 Ω	8.4 VDC	1.2 VDC	0.53 W	
	VB-14S () () U-()	14 V DC	370 Ω	9.8 VDC	1.4 VDC	0.53 W	
	VB-18S () () U-()	18 V DC	610 Ω	12.6 VDC	1.8 VDC	0.53 W	
	VB-24S () () U-()	24 V DC	1,100 Ω	16.8 VDC	2.4 VDC	0.53 W	
	VB-36S () () U-()	36 V DC	2,450 Ω	25.2 VDC	3.6 VDC	0.53 W	
	VB-48S () () U-()	48 V DC	4,400 Ω	33.6 VDC	4.8 VDC	0.53 W	
	VB-60S () () U-()	60 V DC	6,800 Ω	42.0 VDC	6.0 VDC	0.53 W	
	VB-100S () () U-()	100 V DC	18,860 Ω	70.0 VDC	10.0 VDC	0.53 W	

Note: All values in the table are measured at 20 °C.

CHARACTERISTIC DATA

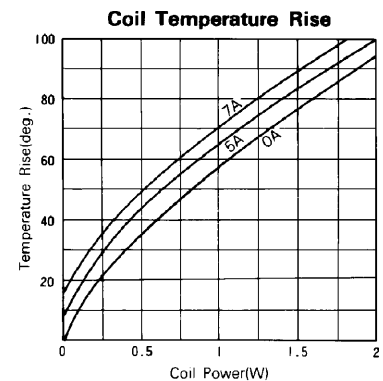
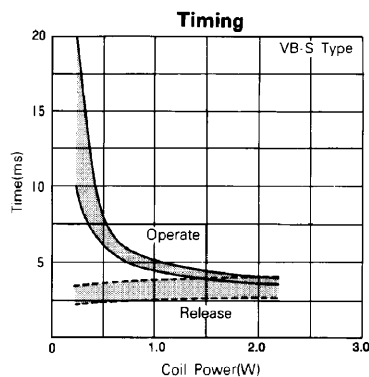
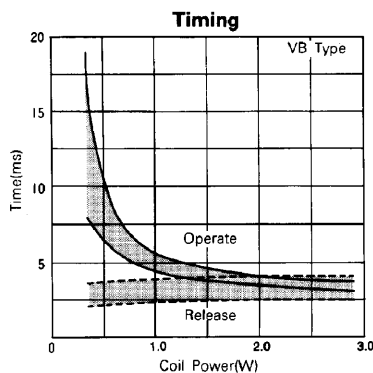

VB SERIES

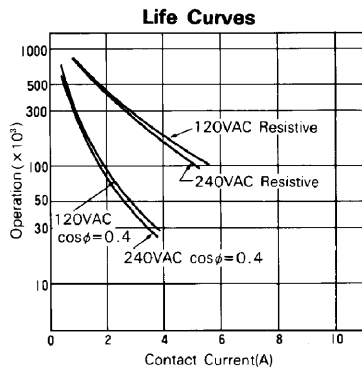
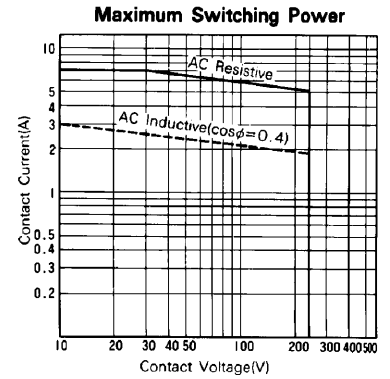
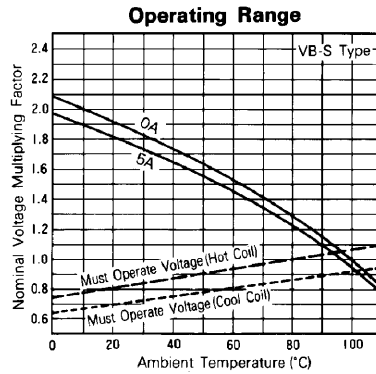
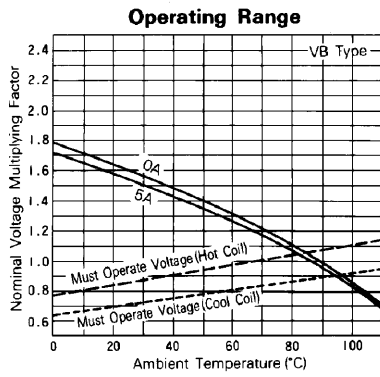

REFERENCE DATA

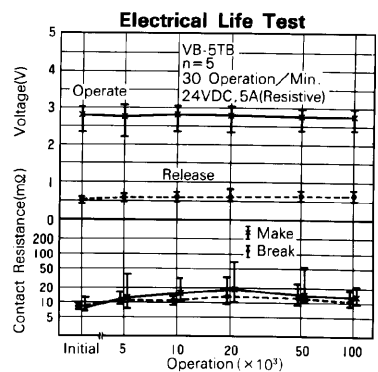
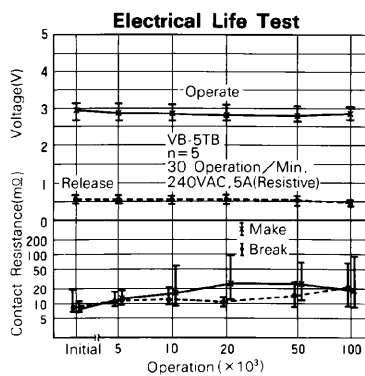
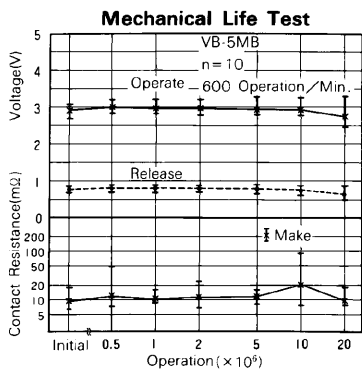
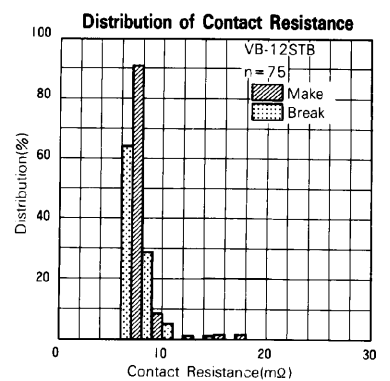
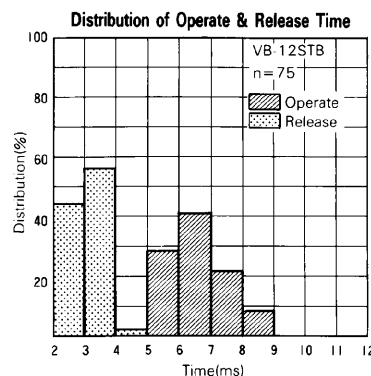
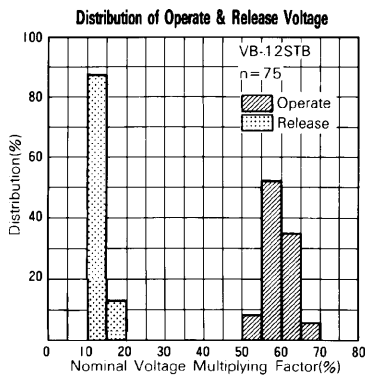

VB SERIES

■ DIMENSIONS

● Dimensions

VB-M type

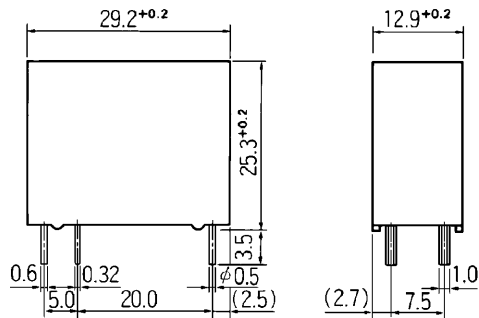

● Schematics

(BOTTOM VIEW)

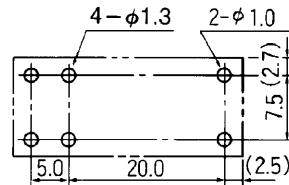

● PC board mounting

hole layout

(BOTTOM VIEW)

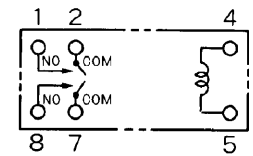

VB type

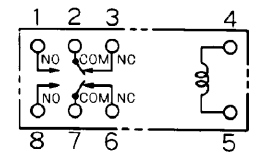
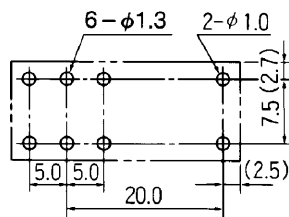
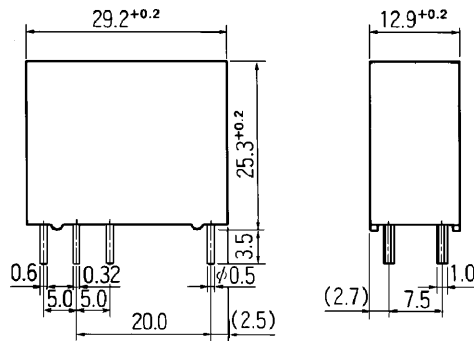

VB-MK type (Plastic sealed type)

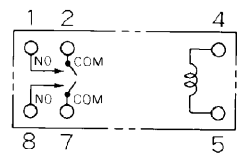
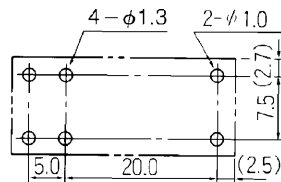
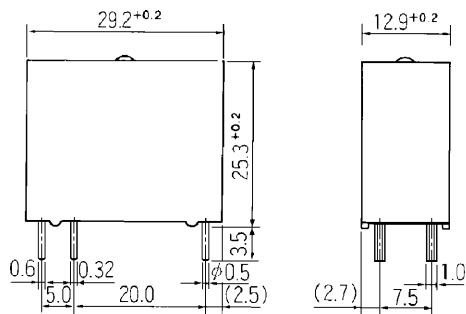

VB-K type (Plastic sealed type)

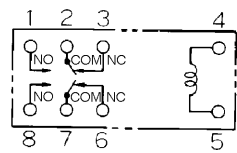
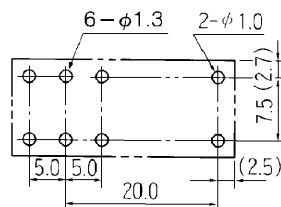
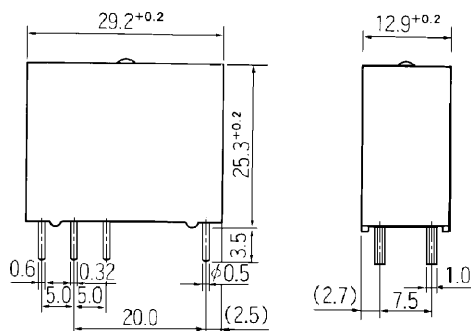

Unit: mm

VB SERIES

VB-MC type (Plastic sealed type with tape)

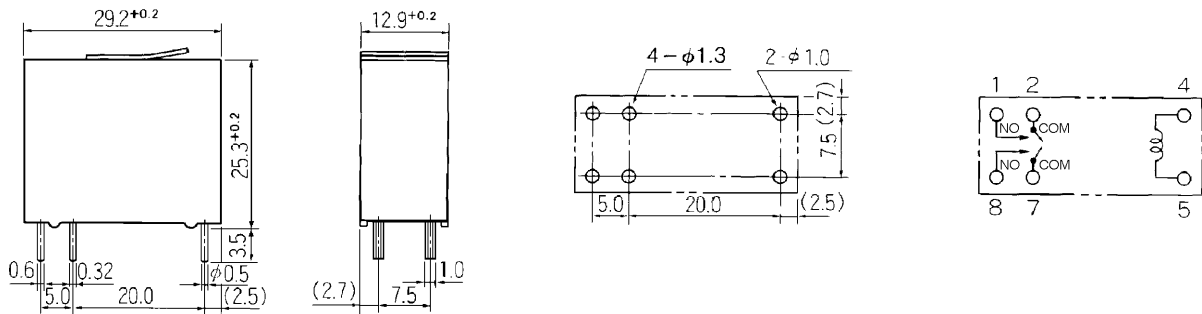

VB-C type (Plastic sealed type with tape)

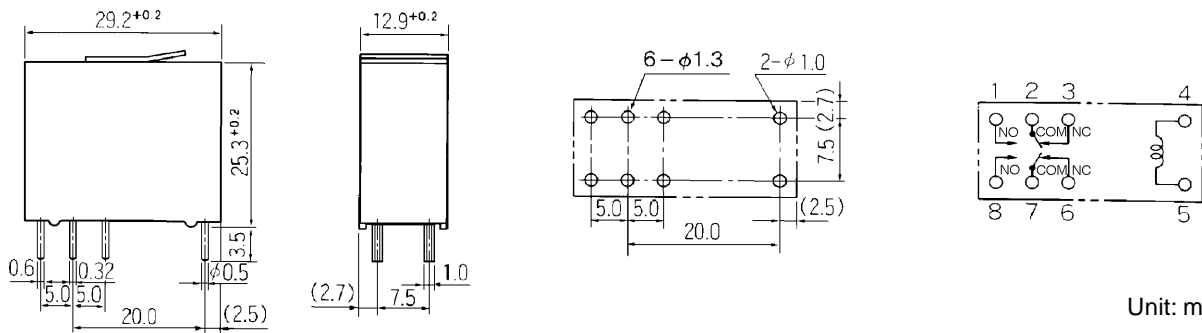

Unit: mm

Fujitsu Components International Headquarter Offices

Japan
Fujitsu Component Limited
Gotanda-Chuo Building
3-5, Higashigotanda 2-chome, Shinagawa-ku
Tokyo 141, Japan
Tel: (81-3) 5449-7010
Fax: (81-3) 5449-2626
Email: promothq@ft.ed.fujitsu.com
Web: www.fcl.fujitsu.com

North and South America
Fujitsu Components America, Inc.
250 E. Caribbean Drive
Sunnyvale, CA 94089 U.S.A.
Tel: (1-408) 745-4900
Fax: (1-408) 745-4970
Email: marcom@fcai.fujitsu.com
Web: www.fcai.fujitsu.com

Europe
Fujitsu Components Europe B.V.
Diamantlaan 25
2132 WV Hoofddorp
Netherlands
Tel: (31-23) 5560910
Fax: (31-23) 5560950
Email: info@fceu.fujitsu.com
Web: www.fceu.fujitsu.com

Asia Pacific
Fujitsu Components Asia Ltd.
102E Pasir Panjang Road
#04-01 Citilink Warehouse Complex
Singapore 118529
Tel: (65) 6375-8560
Fax: (65) 6273-3021
Email: fcal@fcal.fujitsu.com
www.fcal.fujitsu.com

© 2003 Fujitsu Components America, Inc. All company and product names are trademarks or registered trademarks of their respective owners. Rev. 02/18/2003