

Technical Data

49SMLB / SAB / SUB / SNC



Description

The crystals are miniature AT or BT cut strip resonators housed in low profile packages for surface mounting. The parts present a proven metal package technology with a precision molded base and universal contact configuration.

Applications & Features

- Fibre Channel, Ethernet, 56K& Cable Modems, ADSL, ISDN, Audio/Video, Microcontrollers, Remote Control Devices, Network Processors
- 49SNC is interchangeable with popular molded crystal configurations
- Available on tape & reel; 24mm tape, 1000pcs per reel

Pad Connection Configurations

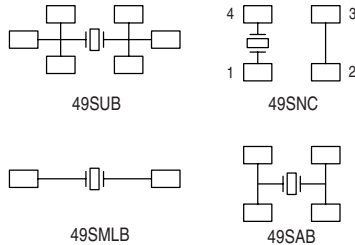

Solder Reflow Guide

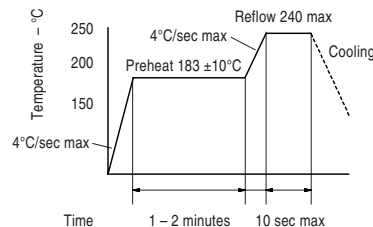

Frequency Range:	3.2 to 29.999 MHz, AT Fundamental 26.8 to 50.000 MHz, BT Fundamental 30.0 to 80.000 MHz, AT 3rd OT
Temperature Range:	Operating: -20 to +70°C (standard - see part number builder for other options) Storage: -55 to +125°C
Freq. Stability Tolerance:	±50 ppm (0 to -100 ppm for BT) -20 to +70°C (standard - see part number builder for other options)
Characteristics at 25°C ±2°C:	Freq. Calibration Tolerance: ±50 ppm (standard - see part number builder for other options) Load Capacitance: 16pF to 32pF or series resonance Effective Series Resistance: 30 to 200Ω (frequency dependent) Drive Level: 25μW correlation, 500μW max Shunt Capacitance: 7pF max
Mechanical:	Shock: MIL-STD-883, Method 2002, Condition B Solderability: MIL-STD-883, Method 2003 Terminal Strength: MIL-STD-202, Method 211, Conditions A and C Vibration: MIL-STD-883, Method 2007, Condition A Solvent Resistance: MIL-STD-202, Method 215 Resistance to Soldering Heat: MIL-STD-202, Method 210, Condition I or J
Environmental:	Gross Leak Test: MIL-STD-883, Method 1014, Condition C Fine Leak Test: MIL-STD-883, Method 1014, Condition A Thermal Shock: MIL-STD-883, Method 1011, Condition A Moisture Resistance: MIL-STD-883, Method 1004

Part Numbering Guide:

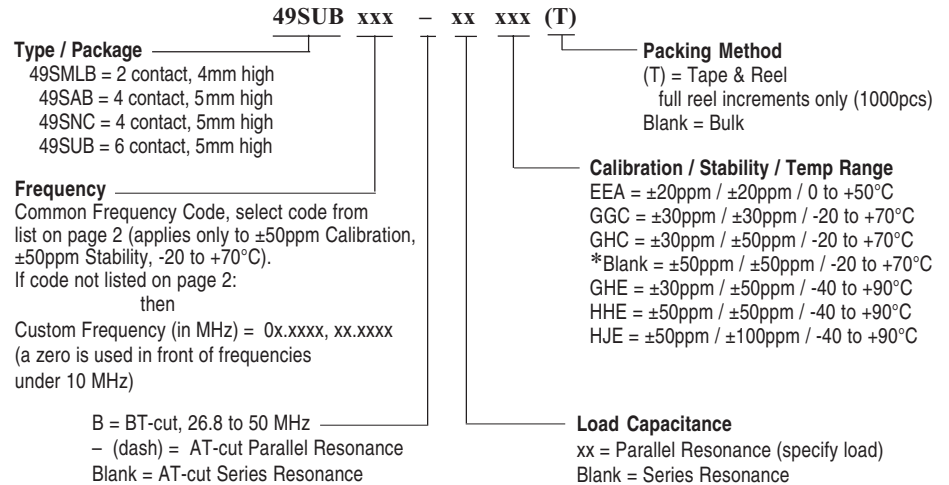

*no code used, as these specs designate standard configuration for this series

Part Number Examples:

Common Freq 20MHz, ±50ppm calib, ±50ppm stability, -20 to +70°C, 12pF = 49SMLB200-12
Common Freq 20MHz, ±50ppm calib, ±50ppm stability, -20 to +70°C, Series = 49SMLB200
Custom Freq 5.1234MHz, ±30ppm calib, ±30ppm stability, -20 to +70°C, 16pF = 49SMLB05.1234-16GGC

Technical Data

49SMLB / SAB / SUB / SNC

Package Details

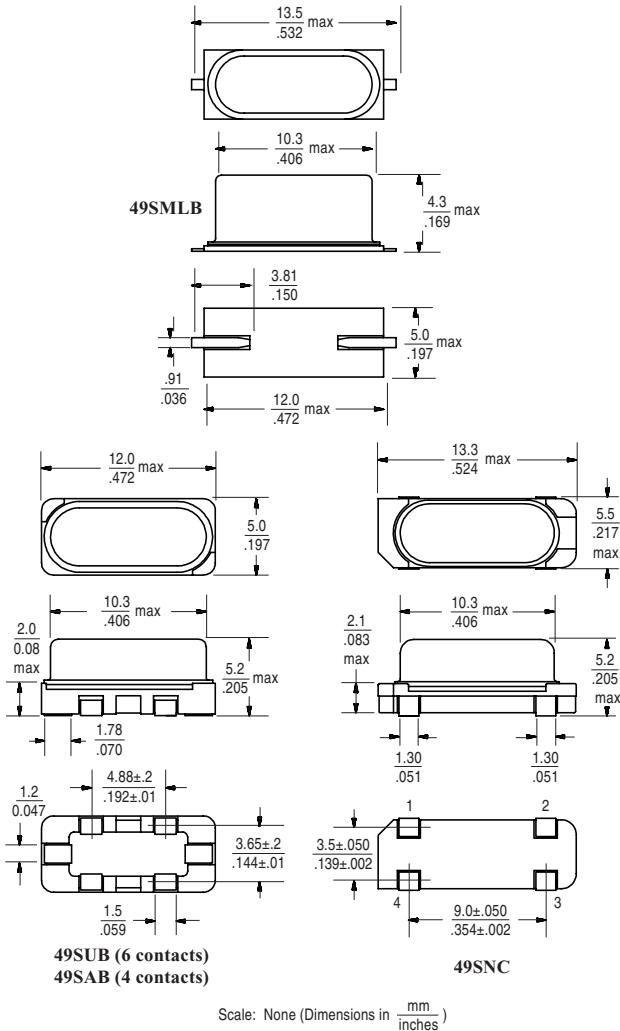

Common Frequencies:

Common frequency codes:
to be used only with ± 50 ppm calibration, ± 50 ppm stability over -20 to $+70^\circ\text{C}$

Frequency MHz	Frequency Code	Max ESR (Fundamental)	Max ESR (3rd OT)
3.579545	035	200	
3.686400	037	160	
4.000000	040	150	
4.915200	049	150	
5.068800	051	120	
6.000000	060	100	
7.372800	073	80	
8.000000	080	80	
10.000000	100	60	
11.059200	111	60	
12.000000	120	60	
12.288000	122	60	
14.318180	143	30	
15.000000	150	30	
16.000000	160	30	
18.000000	180	30	
18.432000	184	30	
19.668000	196	30	
20.000000	200	30	
24.000000	240	30	
24.576000	245	30	
25.000000	250	30	
26.800000	268	30	
28.000000	280	30	
29.491200	294	30	
30.000000	300	30	80
32.000000	320	30	80
32.256000	322	30	80
33.000000	330	30	
33.333000	333	30	
33.868000	338	30	
35.251200	352	30	80
36.000000	360	30	80
40.000000	400	30	80
40.320000	403	30	80
40.960000	409	30	80
42.000000	420	30	80
42.500000	425	30	80
45.000000	450	30	80
46.000000	460	30	80
48.000000	480	30	80
50.000000	500	30	80
52.416000	524	30	80
56.448000	564	30	80
60.000000	600	30	80
66.666667	666	30	80

Recommended Land Patterns

If custom frequency, calibration, stability, temp use:

Line 1: S = SaRonix Designator
- (dash) = separator
xxx = Calib/Stability/Temp Code
YYWW = Date Code

Line 2: Frequency (up to 7 digits including decimal point)
BT-cut = B or
AT-cut Parallel = - (dash) or
AT-cut Series = leave Blank
xx = Load Capacitance (leave blank if Series)

S-xxxYYWW
24.5760-xx

If common frequency and standard specifications:

Line 1: S = SaRonix Designator
YYWW = Date Code

Line 2: Frequency (up to 7 digits including decimal point)
BT-cut = B or
AT-cut Parallel = - (dash) or
AT-cut Series = leave Blank
xx = Load Capacitance (leave blank if Series)

SYWW
24.5760-xx

Solder Reflow Guide

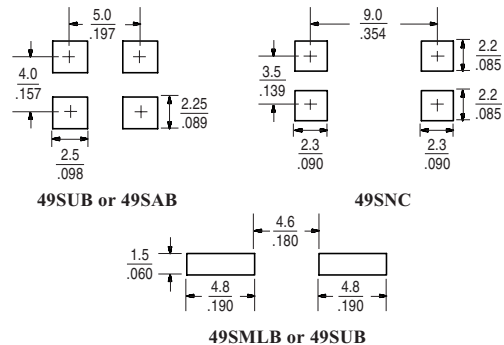

All specifications are subject to change without notice.

DS-153 REV E06