

# フェライトビーズインダクタ (リードタイプ) LEADED FERRITE BEADS INDUCTORS

OPERATING TEMP. -25~+85°C

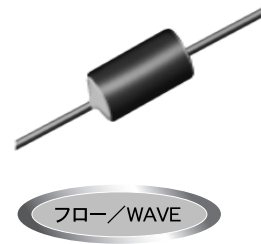

## 特長 FEATURES

- ・損失分の大きなフェライト材料を使用
- ・基板への実装が容易
- ・用途に合わせた幅広いバリエーション
- ・ Use of high loss ferrite material.
- ・ Easy mounting on PC boards.
- ・ Available in a wide range of values and configurations to suit most applications.

## 用途 APPLICATIONS

- ・各種デジタル機器におけるデジタル信号の波形整形、データラインの高周波ノイズ吸収
- ・ Waveform correction of digital signals from digital equipment and absorption of high-frequency noise from data lines.

## 形名表記法 ORDERING CODE

<b>1</b> 形式 FB フェライトビーズインダクタ	<b>3</b> コア寸法 (D寸法) [mm] 03 φ2.5 04 φ3.5 05 5.0 06 6.0 07 7.5	<b>5</b> 公称インピーダンス(Q以上) 例 850 85 121 120 03タイプ除く	<b>6</b> リード加工形状(mm) AB 26.0幅ストレートリードつづら折りテーピング SA 2.5ピッチストレートリードテーピング BB 52.0幅ストレートリードつづら折りテーピング SB 5.0ピッチストレートリードテーピング KD 10.0ピッチ コの字形フォーミング単品 UB 5.0ピッチラジアルフォーミングテーピング KE 12.5ピッチ コの字形フォーミング単品 US 5.0ピッチラジアルフォーミング単品 KF 15.0ピッチ コの字形フォーミング単品 VB 5.0ピッチ両リードフォーミングテーピング NA 2.5ピッチストレートリード単品(FBR) VS 5.0ピッチ両リードフォーミング単品 ストレートリード単品(FBA) NB 5.0ピッチリード単品
<b>2</b> 形状 A アクシシャルリード R ラジアルリード	<b>4</b> 材質コード HA 材質によりインピーダンス特性が異なる VA	<b>7</b> 当社管理記号 -00 標準品	



<b>1</b> Type FB Ferrite Beads	<b>3</b> Core Dimensions [mm] 03 φ2.5 04 φ3.5 05 5.0 06 6.0 07 7.5	<b>5</b> Nominal Impedance example 850 85 121 120 Excluding 03Type	<b>6</b> Lead configuration [mm] AB straight lead (26mm lead space) / ammo SA Straight lead (FBR05 type) / ammo BB straight lead (52mm lead space) / ammo SB Straight lead (FBR07 type) / ammo KD Formed lead (10mm pitch) / bulk UB Radial lead formed / ammo KE Formed lead (12.5mm pitch) / bulk US Formed lead (crimped) / bulk KF Formed lead / bulk (15.0mm pitch) / bulk VB Dual side lead formed (crimped) / ammo NA straight lead (2.5mm pitch) / bulk (FBR) VS Formed lead / bulk straight lead / bulk (FBA) NB Formed lead (crimped) / bulk
<b>2</b> Configuration A Axial lead R Radial lead	<b>4</b> Material code HA Refer to impedance curves for material difference VA	<b>7</b> Internal code -00 Standard Products	

外形寸法 EXTERNAL DIMENSIONS

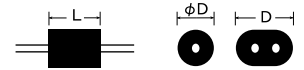

Type	形状 Configurations				Dimensions(mm)(inch)	
	テーピング Taping		単品 Bulk		D	L
	ストレート Straight	フォーミング Formed	ストレート Straight	フォーミング Formed		
FBA 03HA450□-00 03VA450□-00 04HA450□-00 04VA450□-00 04HA600□-00 04VA600□-00 04HA900□-00 04VA900□-00					2.5±0.2 (0.098±0.008)	4.5±0.3 (0.177±0.012)
					3.5±0.2 (0.138±0.008)	4.5±0.3 (0.177±0.012)
					3.5±0.2 (0.138±0.008)	6.0 <sup>+0.5</sup> <sub>-0</sub> (0.236 <sup>+0.020</sup> <sub>-0</sub> )
					3.5±0.2 (0.138±0.008)	9.0±0.5 (0.354±0.020)
FBR 05VA121□-00 06HA850NA-00 06VA850NA-00 06HA121NA-00 06VA121NA-00 07HA850□-00 07VA850□-00 07HA121□-00 07VA121□-00	—		—		5.0max. (0.197max.)	7.5 (0.295)
	—	—	—		6.0±0.5 (0.236±0.020)	5.0 (0.197)
	—	—	—		6.0±0.5 (0.236±0.020)	7.0 (0.276)
	—		—		7.5±0.5 (0.295±0.020)	5.5 (0.217)
	—	—	—		7.5±0.5 (0.295±0.020)	7.5 (0.295)
	—	—	—		7.5±0.5 (0.295±0.020)	7.5 (0.295)

形名の□にはリード加工形状記号が入ります。 □ Please specify the lead configuration code. Unit : mm (inch)  
 ※リード線径d寸法は、0.65±0.05mm 但し、FBR05,07タイプのφd寸法は0.6±0.05mm  
 Note: Lead diameter (φd) shall fall within a range of 0.65mm±0.05mm, FBR05, and FBR07 types however, will have a lead diameter (φd) range of 0.6mm±0.05mm.

アイテム一覧 PART NUMBERS

形名 Ordering code	インピーダンス Impedance [Ω]min.	インピーダンス測定周波数 Measuring frequency[MHz]		定格電流 Rated current[A]max.	
		材質 Material		材質 Material	
		HA	VA	HA	VA
FBA 03△450□-00 04△450□-00 04△600□-00 04△900□-00	35.0	50	100	7.0	7.0
	45.0	50	100	7.0	7.0
	60.0	50	100	7.0	7.0
	90.0	50	100	7.0	7.0
FBR 05VA121□-00 06△850NA-00 06△121NA-00 07△850□-00 07△121□-00	120.0	—	100	—	7.0
	85.0	50	100	7.0	7.0
	120.0	50	100	7.0	7.0
	85.0	50	100	7.0	7.0
	120.0	50	100	7.0	7.0

形名の△には材質記号(HA,VA)、□にはリード加工形状記号が入ります。  
 △ Please specify material codes(HA,VA) and □ lead configuration code.  
 ※直流抵抗 DC Resistance : 0.01Ωmax、絶縁抵抗 Insulation resistance : 1.0MΩmin

セレクションガイド  
Selection Guide

アイテム一覧  
Part Numbers

特性図  
Electrical Characteristics

梱包  
Packaging

信頼性  
Reliability Data

使用上の注意  
Precautions



etc

インピーダンス周波数特性

IMPEDANCE-vs-FREQUENCY CHARACTERISTICS

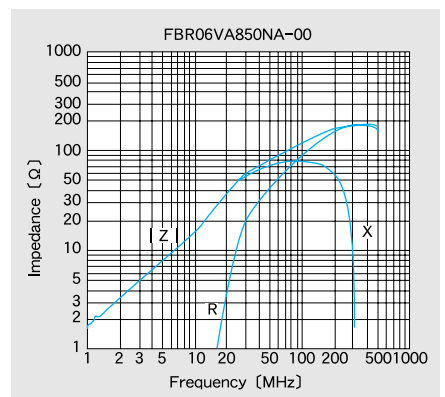
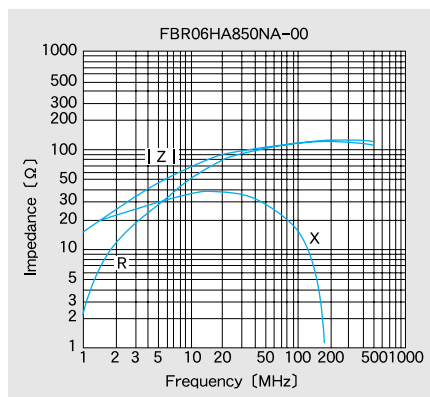
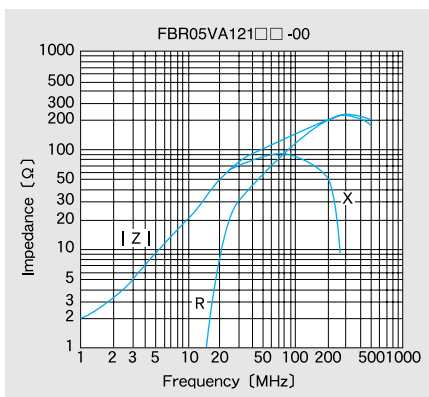
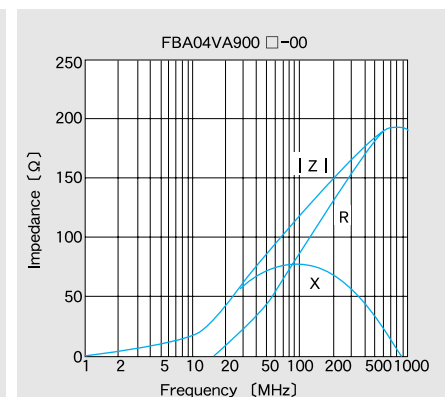
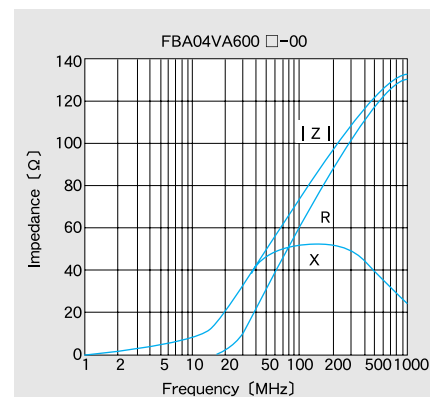
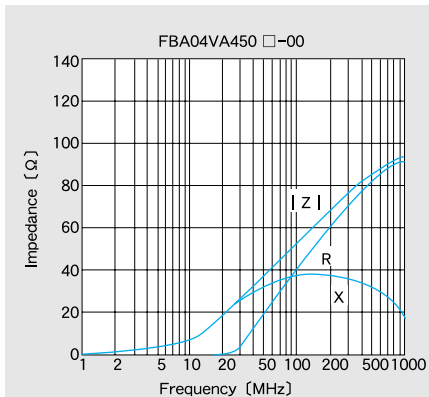
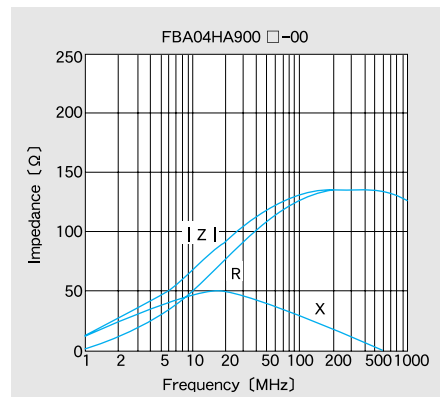
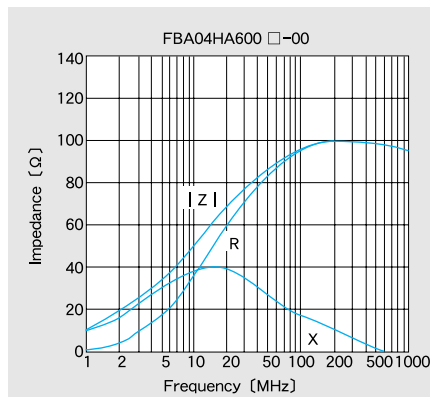
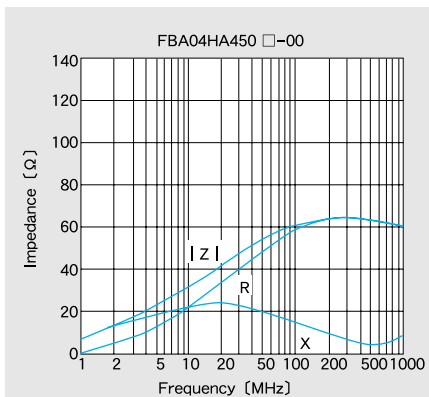
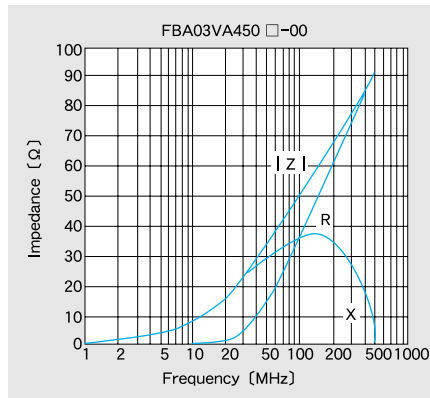
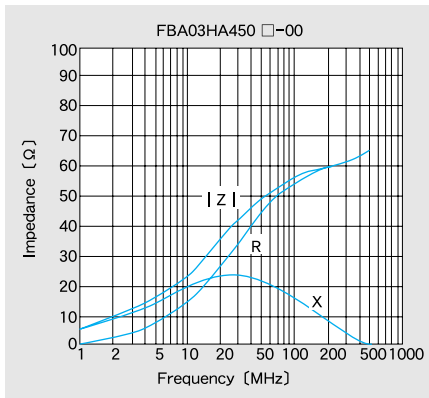

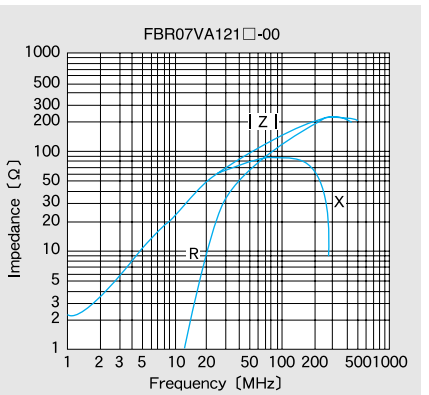
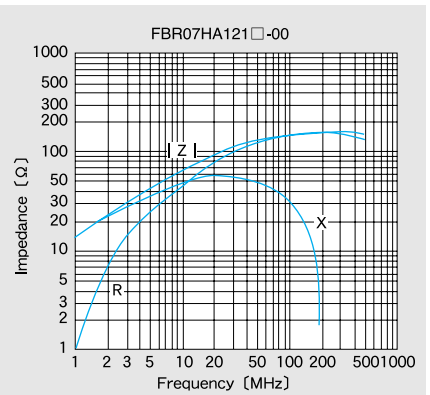
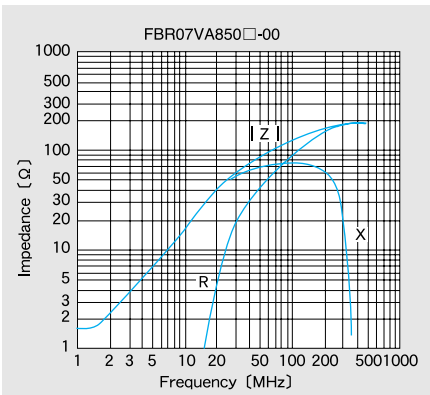
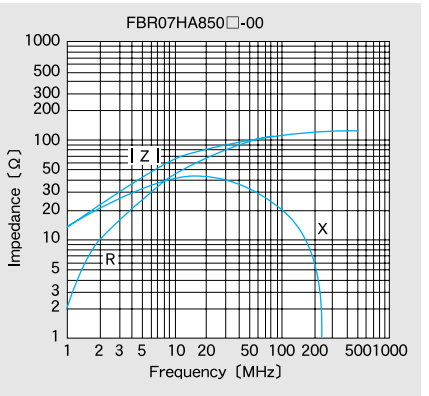
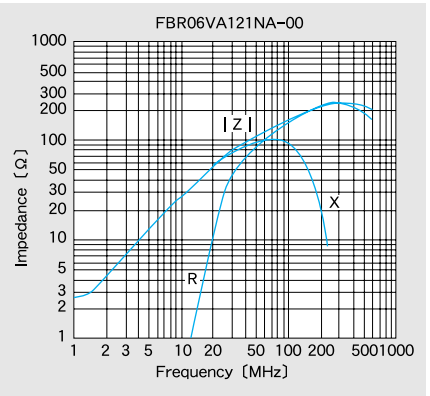
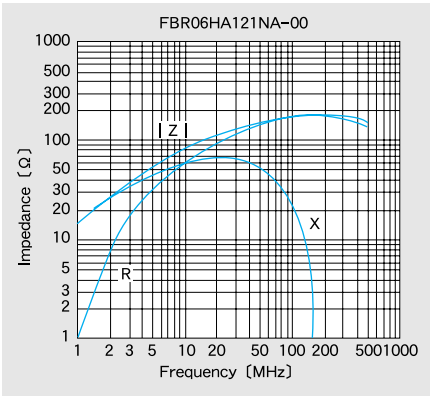

Measured by HP4191A

# 梱包 PACKAGING

## ①最小受注単位数 Minimum Quantity

アキシシャルリード Axial lead(FBA)

Type	リード加工 形状記号 Lead configuration	標準数量 Standard quantity (pcs)	
		袋詰め Bulk	テーピング Taped つづら折り Ammo
FBA03	NA	1000	—
	AB, BB	—	2000
	KE, KF	500	—
	KD	1000	—
	US	1000	—
FBA04	UB	—	3000
	NA, KD, US	1000	—
	KE, KF, VS	500	—
	AB, BB	—	1000
	VB, UB	—	3000

ラジアルリード Radial lead(FBR)

Type	リード加工 形状記号 Lead configuration	標準数量 Standard quantity (pcs)	
		袋詰め Bulk	テーピング Taped つづら折り Ammo
FBR05	NA	1000	—
	SA	—	2000
FBR06	NA	1000	—
FBR07	NB	1000	—
	SB	—	2000

Unit : mm(inch)

## ②単品寸法 Bulk dimensions

アキシシャルリード Axial lead(FBA)

NA形状

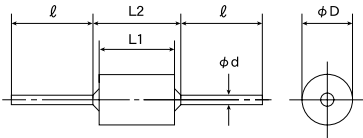

Type	寸法 Dimensions (mm) (inch)				
	φD	L1	L2	φd	ℓ
FBA03□450	2.5±0.2 (0.098±0.008)	4.5±0.3 (0.177±0.012)	6.5max. (0.256max.)	0.65±0.05 (0.026±0.002)	18min. (0.709min.)
FBA04□450	3.5±0.2 (0.138±0.008)	4.5±0.3 (0.177±0.012)	6.5max. (0.335max.)		
FBA04□600	3.5±0.2 (0.138±0.008)	6.0 <sup>+0.5</sup> <sub>-0</sub> (0.236 <sup>+0.020</sup> <sub>-0</sub> )	8.5max. (0.335max.)		
FBA04□900	3.5±0.2 (0.138±0.008)	9.0±0.5 (0.354±0.020)	11.0max. (0.433max.)		

Unit : mm(inch)

US形状

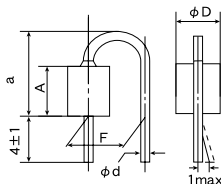

Type	寸法 Dimensions (mm) (inch)				
	φD	A	a	F	φd
FBA03□450	2.5±0.2 (0.098±0.008)	4.5±0.3 (0.177±0.012)	9.0max. (0.354max.)	5±1 (0.197±0.039)	0.65±0.05 (0.026±0.002)
FBA04□450	3.5±0.2 (0.138±0.008)	4.5±0.3 (0.177±0.012)	9.0max. (0.354max.)		

Unit : mm(inch)

KD/KE/KF 形状

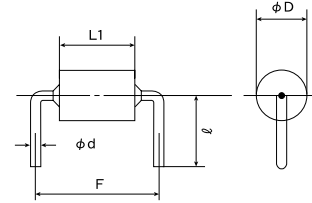

Type	リード加工形状記号 LEAD SYMBOL	寸法 Dimensions (mm) (inch)				
		φD	F	L1	φd	ℓ
FBA03□450	KD	2.5±0.2 (0.098±0.008)	10.0±1.0 (0.394±0.040)	4.5±0.3 (0.177±0.012)	0.65±0.05 (0.026±0.020)	7±2 (0.276±0.079)
FBA04□450		3.5±0.2 (0.138±0.008)	10.0±1.0 (0.394±0.040)	4.5±0.3 (0.177±0.012)		7.5±2 (0.295±0.079)
FBA04□600		3.5±0.2 (0.138±0.008)	10.0±1.0 (0.394±0.040)	6.0 <sup>+0.5</sup> <sub>-0</sub> (0.236 <sup>+0.020</sup> <sub>-0</sub> )		7.5±2 (0.295±0.079)
FBA03□450	KE	2.5±0.2 (0.098±0.008)	12.5±1.0 (0.492±0.004)	4.5±0.3 (0.177±0.012)	0.65±0.05 (0.026±0.020)	7±2 (0.276±0.079)
FBA04□450		3.5±0.2 (0.138±0.008)	12.5±1.0 (0.492±0.004)	4.5±0.3 (0.177±0.012)		7.5±2 (0.295±0.079)
FBA04□600		3.5±0.2 (0.138±0.008)	12.5±1.0 (0.492±0.004)	6.0 <sup>+0.5</sup> <sub>-0</sub> (0.236 <sup>+0.020</sup> <sub>-0</sub> )		7.5±2 (0.295±0.079)
FBA04□900	KF	3.5±0.2 (0.138±0.008)	12.5±1.0 (0.492±0.004)	9.0±0.5 (0.354±0.020)	0.65±0.05 (0.026±0.020)	7.5±2 (0.295±0.079)
FBA03□450		2.5±0.2 (0.098±0.008)	15.0±1.0 (0.591±0.004)	4.5±0.3 (0.177±0.012)		7±2 (0.276±0.079)
FBA04□450		3.5±0.2 (0.138±0.008)	15.0±1.0 (0.591±0.004)	4.5±0.3 (0.177±0.012)		7.5±2 (0.295±0.079)
FBA04□600	KF	3.5±0.2 (0.138±0.008)	15.0±1.0 (0.591±0.004)	6.0 <sup>+0.5</sup> <sub>-0</sub> (0.236 <sup>+0.020</sup> <sub>-0</sub> )	0.65±0.05 (0.026±0.020)	7.5±2 (0.295±0.079)
FBA04□900		3.5±0.2 (0.138±0.008)	15.0±1.0 (0.591±0.004)	9.0±0.5 (0.354±0.020)		7.5±2 (0.295±0.079)

Unit : mm(inch)

VS 形状

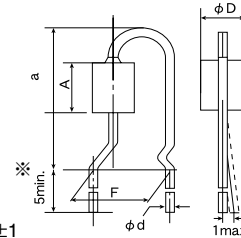

※900タイプのみ5±1

Type	寸法 Dimensions (mm) (inch)				
	φD	A	a	F	φd
FBA04□450	3.5±0.2 (0.138±0.008)	4.5±0.3 (0.177±0.012)	12.5max. (0.492max.)	5±1 (0.197±0.039)	0.65±0.05 (0.026±0.002)
FBA04□600	3.5±0.2 (0.138±0.008)	6.0 <sup>+0.5</sup> <sub>-0</sub> (0.236 <sup>+0.020</sup> <sub>-0</sub> )	12.5max. (0.492max.)	5±1 (0.197±0.039)	0.65±0.05 (0.026±0.002)
FBA04□900	3.5±0.2 (0.138±0.008)	9.0±0.5 (0.354±0.020)	16.0max. (0.630max.)	5±1 (0.197±0.039)	0.65±0.05 (0.026±0.002)

Unit : mm(inch)

# 梱包 PACKAGING

ラジアルリード Radial lead(FBR)

NA形状

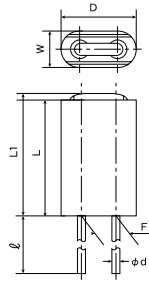

Type	寸法 Dimensions (mm) (inch)				
	D	L	L1	$\phi d$	$\ell$
FBR05VA121	5.0max. (0.197max.)	7.5 (0.295)	9.0max. (0.354max.)	0.65±0.05 (0.026±0.002)	10 <sup>+3</sup> <sub>-5</sub> (0.394 <sup>+0.118</sup> <sub>-0.197</sub> )
FBR06□850	6±0.5 (0.236±0.020)	5.0 (0.197)	7.0max. (0.276max.)	0.65±0.05 (0.026±0.002)	10 <sup>+3</sup> <sub>-5</sub> (0.394 <sup>+0.118</sup> <sub>-0.197</sub> )
FBR06□121	6±0.5 (0.236±0.020)	7.0 (0.276)	9.0max. (0.354max.)	0.65±0.05 (0.026±0.002)	10 <sup>+3</sup> <sub>-5</sub> (0.394 <sup>+0.118</sup> <sub>-0.197</sub> )
	W	F			
FBR05VA121	2.5max. (0.098max.)	2.5±1 (0.098±0.039)			
FBR06□850	3.0±0.5 (0.118±0.020)	2.5±1 (0.098±0.039)			
FBR06□121	3.0±0.5 (0.118±0.020)	2.5±1 (0.098±0.039)			

Unit : mm(inch)

NB形状

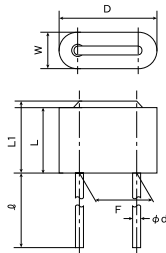

Type	寸法 Dimensions (mm) (inch)				
	D	L	L1	$\phi d$	$\ell$
FBR07□850	7.5±0.5 (0.295±0.020)	5.5 (0.217)	7.0max. (0.276max.)	0.6±0.05 (0.024±0.002)	5 <sup>+1</sup> <sub>-2</sub> (0.197 <sup>+0.039</sup> <sub>-0.079</sub> )
FBR07□121	7.5±0.5 (0.295±0.020)	7.5 (0.295)	9.0max. (0.354max.)	0.6±0.05 (0.024±0.002)	5 <sup>+1</sup> <sub>-2</sub> (0.197 <sup>+0.039</sup> <sub>-0.079</sub> )
	W	F			
FBR07□850	2.5max. (0.098max.)	5 <sup>+1</sup> <sub>-0.5</sub> (0.197 <sup>+0.039</sup> <sub>-0.020</sub> )			
FBR07□121	2.5max. (0.098max.)	5 <sup>+1</sup> <sub>-0.5</sub> (0.197 <sup>+0.039</sup> <sub>-0.020</sub> )			

Unit : mm(inch)

③テーピング寸法 Taping Dimensions

AB (a : 26mm) 形状  
(1.02inch lead space)

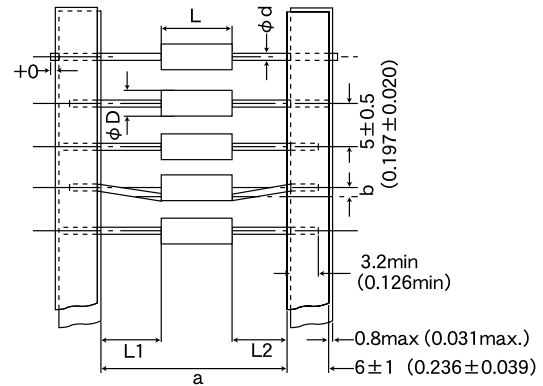

Type	寸法 Dimensions						最小挿入ピッチ Minimum insertion pitch
	D	L	a	b	$ L_1-L_2 $	$\phi d$	
FBA03	2.5±0.2 (0.098±0.008)	4.5±0.3 (0.177±0.012)	26 <sup>+1.5</sup> <sub>-0</sub> (1.02 <sup>+0.059</sup> <sub>-0</sub> )	1.0max (0.039max)	1.0max (0.039max)	0.65±0.05 (0.026±0.002)	10.0 (0.394)
FBA04	3.5±0.2 (0.138±0.008)	4.5±0.3 (0.177±0.012)	26 <sup>+1.5</sup> <sub>-0</sub> (1.02 <sup>+0.059</sup> <sub>-0</sub> )	1.0max (0.039max)	1.0max (0.039max)	0.65±0.05 (0.026±0.002)	10.0 (0.394)

Unit : mm(inch)

B□ (a : 52mm) 形状  
(2.05 inches lead space)

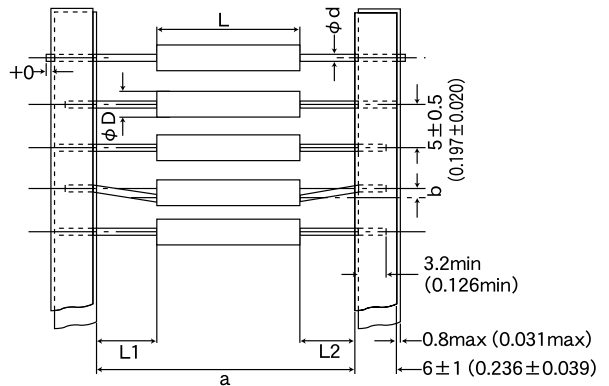

Type	寸法 Dimensions						最小挿入ピッチ Minimum insertion pitch
	D	L	a	b	$ L_1-L_2 $	$\phi d$	
FBA03	2.5±0.2 (0.098±0.008)	4.5±0.3 (0.177±0.012)	52 <sup>+2</sup> <sub>-1</sub> (2.05 <sup>+0.079</sup> <sub>-0.039</sub> )	1.2max (0.047max)	1.0max (0.039max)	0.65±0.05 (0.026±0.002)	10.0 (0.394)
FBA04	3.5±0.2 (0.138±0.008)	4.5±0.3 (0.177±0.012)	52 <sup>+2</sup> <sub>-1</sub> (2.05 <sup>+0.079</sup> <sub>-0.039</sub> )	1.2max (0.047max)	1.0max (0.039max)	0.65±0.05 (0.026±0.002)	10.0 (0.394)

Unit : mm(inch)

SA (F : 2.5mm pitch) 形状  
(0.098 inches)

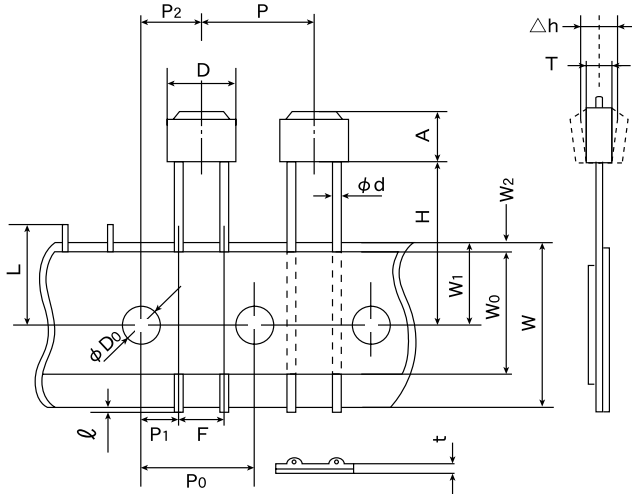

SB (F : 5mm pitch) 形状  
(0.197 inches)

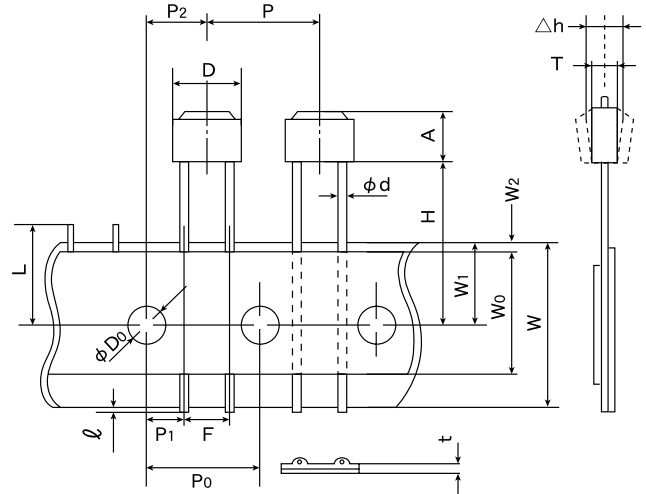

寸法 Type	記号 Symbol	寸法 Dimensions	記号 Symbol	寸法 Dimensions
FBR05	A	121 : 9.0max. (0.354max.)	W	18 <sup>+1.0</sup> <sub>-0.5</sub> (0.709 <sup>+0.039</sup> <sub>-0.020</sub> )
			W <sub>0</sub>	12.5min. (0.492min.)
	T	2.5max. (0.098max.)	W <sub>1</sub>	9 <sup>+0.75</sup> <sub>-0.5</sub> (0.354 <sup>+0.039</sup> <sub>-0.020</sub> )
	D	5.0max. (0.197max.)	W <sub>2</sub>	3max.*2 (0.118max.)
	H	18.0 <sup>+2.0</sup> <sub>-0</sub> (0.709 <sup>+0.079</sup> <sub>-0</sub> )	ℓ	1.0max. (0.039max.)
	P	12.7±1.0 (0.500±0.039)	φD <sub>0</sub>	4±0.3 (0.157±0.012)
	P <sub>0</sub>	12.7±0.3*1 (0.500±0.039)	φd	0.65±0.05 (0.026±0.002)
	P <sub>1</sub>	5.1±0.7 (0.201±0.028)	L	11.0max. (0.433max.)
	P <sub>2</sub>	6.35±1.3 (0.250±0.051)	t	0.7±0.2 (0.028±0.008)
	F	2.5 <sup>+1.0</sup> <sub>-0.5</sub> (0.098 <sup>+0.039</sup> <sub>-0.020</sub> )		
△h	0±2 (0±0.079)			

Unit : mm(inch)

※1 20ピッチにつき、累積誤差±2mm以内。  
 ※2 貼付テープは、台紙よりはみ出さないこと。  
 ※1 Accumulated error for 20 pitches is ±2mm.  
 ※2 Bonding tape must not protrude from the base tape.

寸法 Type	記号 Symbol	寸法 Dimensions	記号 Symbol	寸法 Dimensions
FBR07	A	121 : 9.0max. (0.354max.) 850 : 7.0max. (0.276max.)	W	18 <sup>+1.0</sup> <sub>-0.5</sub> (0.709 <sup>+0.039</sup> <sub>-0.020</sub> )
			W <sub>0</sub>	12.5min. (0.492min.)
	T	2.5max. (0.098max.)	W <sub>1</sub>	9 <sup>+0.75</sup> <sub>-0.5</sub> (0.354 <sup>+0.039</sup> <sub>-0.020</sub> )
	D	7.5±0.5 (0.925±0.020)	W <sub>2</sub>	3max.*2 (0.118max.)
	H	18.0 <sup>+2.0</sup> <sub>-0</sub> (0.709 <sup>+0.079</sup> <sub>-0</sub> )	ℓ	1.0max. (0.039max.)
	P	12.7±1.0 (0.500±0.039)	φD <sub>0</sub>	4±0.3 (0.157±0.012)
	P <sub>0</sub>	12.7±0.3*1 (0.500±0.012)	φd	0.6±0.05 (0.024±0.002)
	P <sub>1</sub>	3.85±0.8 (0.152±0.028)	L	11.0max. (0.433max.)
	P <sub>2</sub>	6.35±1.3 (0.250±0.051)	t	0.7±0.2 (0.028±0.008)
	F	5 <sup>+1.0</sup> <sub>-0.5</sub> (0.197 <sup>+0.039</sup> <sub>-0.020</sub> )		
△h	0±2 (0±0.079)			

Unit : mm(inch)

※1 20ピッチにつき、累積誤差±2mm以内。  
 ※2 貼付テープは、台紙よりはみ出さないこと。  
 ※1 Accumulated error for 20 pitches is ±2mm.  
 ※2 Bonding tape must not protrude from the base tape.

UB 形状

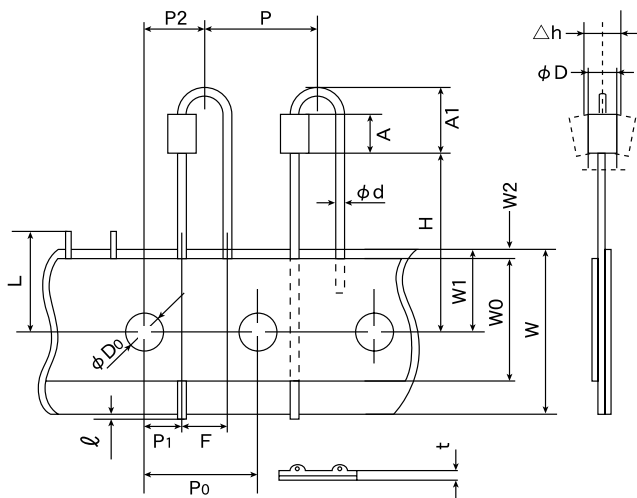

VB 形状

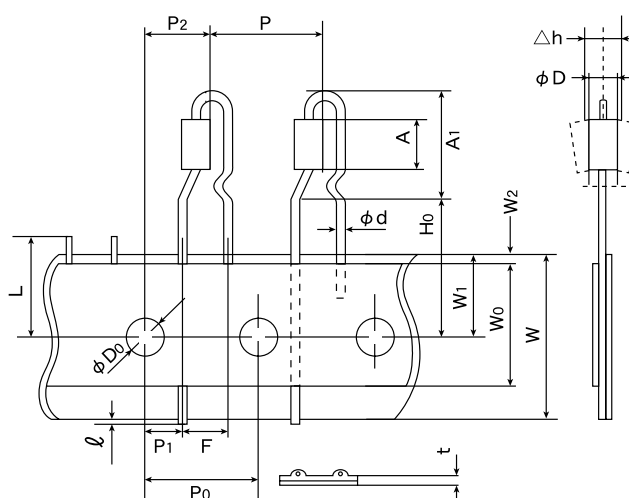

寸法 Type	記号 Symbol	寸法 Dimensions	記号 Symbol	寸法 Dimensions
FBA03□450 FBA04□450	A	4.5±0.3 (0.177±0.012)	Δh	0±2 (0±0.079)
	A1	9.0max. (0.354max.)	W	18 <sup>+1.0</sup> <sub>-0.5</sub> (0.709 <sup>+0.039</sup> <sub>-0.020</sub> )
	φD	03 : 2.7max. (0.106max.) 04 : 3.7max. (0.146max.)	W0	12.5min. (0.492min.)
			W1	9 <sup>+0.75</sup> <sub>-0.5</sub> (0.354 <sup>+0.039</sup> <sub>-0.020</sub> )
	H	20.0 <sup>+0.5</sup> <sub>-1.0</sub> (0.787 <sup>+0.020</sup> <sub>-0.039</sub> )	W2	3.0max.*2 (0.118max.)
	P	12.7±0.1 (0.500±0.039)	ℓ	1.0max. (0.039max.)
	P0	12.7±0.3 *1 (0.500±0.012)	φD0	4.0±0.3 (0.157±0.012)
	P1	3.85±0.8 (0.152±0.032)	φd	0.65±0.05 (0.026±0.002)
	P2	6.35±1.3 (0.250±0.051)	L	11.0max. (0.433max.)
F	5.0±1.0 (0.197±0.039)	t	0.7±0.2 (0.028±0.008)	

※1 20ピッチにつき、累積誤差±2mm以内。  
 ※2 貼付テープは、台紙よりはみ出さないこと。  
 ※1 Accumulated error for 20 pitches is ±2mm.  
 ※2 Bonding tape must not protrude from the base tape.

Unit : mm(inch)

寸法 Type	記号 Symbol	寸法 Dimensions	記号 Symbol	寸法 Dimensions
FBA04□450 FBA04□600 FBA04□900	A	450: 4.5±0.3 (0.177±0.012)	F	5.0±1.0 (0.197±0.039)
		600: 6.0 <sup>+0.5</sup> <sub>-0</sub> (0.236 <sup>+0.020</sup> <sub>-0</sub> )	Δh	0±2 (0±0.079)
		900: 9.0±0.5 (0.354±0.020)	W	18 <sup>+1.0</sup> <sub>-0.5</sub> (0.709 <sup>+0.039</sup> <sub>-0.020</sub> )
	A1	450: 12.5max. (0.492max.)	W0	12.5min. (0.492min.)
		900: 16.0max. (0.630max.)	W1	9 <sup>+0.75</sup> <sub>-0.5</sub> (0.354 <sup>+0.039</sup> <sub>-0.020</sub> )
	φD	3.7max. (0.146max.)	W2	3.0max.*2 (0.118max.)
	H0	16.0±0.5 (0.650±0.020)	ℓ	1.0max. (0.039max.)
	P	12.7±1.0 (0.500±0.039)	φD0	4.0±0.3 (0.157±0.012)
	P0	12.7±0.3 *1 (0.500±0.012)	φd	0.65±0.05 (0.026±0.002)
P1	3.85±0.8 (0.152±0.032)	L	11.0max. (0.433max.)	
P2	6.35±1.3 (0.250±0.051)	t	0.7±0.2 (0.028±0.008)	

※1 20ピッチにつき、累積誤差±2mm以内。  
 ※2 貼付テープは、台紙よりはみ出さないこと。  
 ※1 Accumulated error for 20 pitches is ±2mm.  
 ※2 Bonding tape must not protrude from the base tape.

Unit : mm(inch)



Item	Specified Value								Test Method and Remarks
	LA02 Type/ LA03 Type	LA04 Type	LA05 Type	LHL□□□	FBA/FBR	LAV35	FL05□ Type	FL06BT Type	
1. Operating temperature Range	-25~+105°C				-25~+85°C	-25~+105°C			LA・FL : Including self-generated heat  LHL□□□ : Including self-generated heat [LHL□□□]
2. Storage temperature Range	-40~+85°C								
3. Rated current	Within the specified tolerance								LA : The maximum DC value having inductance within 10% and temperature increase within 20°C by the application of DC bias.  LHL□□□・LAV35 : The maximum DC value having inductance decrease within 10% and temperature increase within the following specified temperature by the application of DC bias. Reference temperature : 20°C(LHL06, LAV35) : 25°C(LHL08, LHL10, LHL13) : 30°C(LHLC06, LHLZ06, LHL16, LHLP□□)  FB : No disconnection or appearance abnormality by continuous current application for 30 min. Change after the application shall be within ±20% of the initial value. This is not guaranteed for electrical characteristics during current application.  FL : The maximum DC value having temperature rise within specified value.
4. Impedance					Within the specified tolerance			Refer to individual specification	FB : Measuring equipment : Impedance analyzer (HP4191A) or its equivalent Measuring frequency : Specified frequency  FL06BT : Measuring equipment : 4291A (HP) or its equivalent Measuring frequency : Specified frequency
5. Inductance	Within the specified tolerance					Within the specified tolerance			LA : Measuring equipment : LCR meter(HP4285A + HP42851A or its equivalent) Measuring frequency : Specified frequency LHL□□□ : Measuring equipment : Q meter(HP4285A+HP42851A or its equivalent) LCR meter( HP4262A) or its equivalent(at 1KHz) Measuring frequency : Specified frequency  LAV35 : Measuring equipment : Q meter(HP4285A+HP42851A or its equivalent) Measuring frequency : Specified frequency  FL05R□ : Measuring equipment : HP4262A or its equivalent. Measuring frequency : 1kHz

Item	Specified Value								Test Method and Remarks												
	LA02 Type/ LA03 Type	LA04 Type	LA05 Type	LHL□□□	FBA/FBR	LAV35	FL05□ Type	FL06BT Type													
6.Q	Within the specified tolerance					Within the specified tolerance			LA : Measuring equipment : LCR meter(HP4285A+HP42851A or its equivalent) Measuring frequency : Specified frequency  LHL□□□ · LAV35(except LHLP) : Measuring equipment : Q meter(HP4285A+HP42851A or its equivalent) Q meter(HP4342A) or its equivalent Measuring frequency : Specified frequency												
7.DC Resistance	Within the specified tolerance								LA : Measuring equipment : low ohmmeter (A&D AD5812 or its equivalent)  LHL□□□ · FB · LAV35 · FL : Measuring equipment : DC ohmmeter												
8.Self resonance frequency	Within the specified tolerance					Within the specified tolerance			LA : Measuring equipment : Network analyzer(Anritsu MS620J or its equivalent)  LHL□□□ · LAV35(except LHLP) : Measuring equipment : (HP4191A, 4192A) its equivalent												
9.Temperature characteristic	$\Delta L/L$ : Within±5%			$\Delta L/L$ : Within±7%		$\Delta L/L$ : Within±5%			LA : Change of maximum inductance deviation in step 1to5 <table border="1"> <thead> <tr> <th>step</th> <th>Temperature(°C)</th> </tr> </thead> <tbody> <tr> <td>1</td> <td>20</td> </tr> <tr> <td>2</td> <td>-25 (Minimum operating temperature)</td> </tr> <tr> <td>3</td> <td>20 (Standard temperature)</td> </tr> <tr> <td>4</td> <td>+85 (Maximum operating temperature)</td> </tr> <tr> <td>5</td> <td>20</td> </tr> </tbody> </table> LHL · LAV35 : [LHL□□□, LAV35] Change of maximum inductance deviation in step 1to5 Temperature at step 1 : 20°C Temperature at step 2 : Minimum operating temperature Temperature at step 3 : 20°C (Standard temperature) Temperature at step 4 : Maximum operating temperature Temperature at step 5 : 20°C	step	Temperature(°C)	1	20	2	-25 (Minimum operating temperature)	3	20 (Standard temperature)	4	+85 (Maximum operating temperature)	5	20
step	Temperature(°C)																				
1	20																				
2	-25 (Minimum operating temperature)																				
3	20 (Standard temperature)																				
4	+85 (Maximum operating temperature)																				
5	20																				

Item	Specified Value								Test Method and Remarks																					
	LA02 Type/ LA03 Type	LA04 Type	LA05 Type	LHL□□□	FBA/FBR	LAV35	FL05□ Type	FL06BT Type																						
10. Terminal strength : tensile force	No abnormality such as cut lead, or looseness.			No abnormality such as cut lead, or looseness.	No abnormality such as cut lead, or looseness.				LA : Apply the stated tensile force progressively in the direction to draw terminal. <table border="1"> <tr> <th>force(N)</th> <th>duration(S)</th> </tr> <tr> <td>25</td> <td>5</td> </tr> </table> LHL□□□ · LAV : Apply the stated tensile force progressively in the direction to draw terminal. <table border="1"> <tr> <th>Nominal wire diameter tensile <math>\phi d</math>(mm)</th> <th>force (N)</th> <th>duration(S)</th> </tr> <tr> <td>0.3 &lt; <math>\phi d</math> ≤ 0.5</td> <td>5</td> <td rowspan="3">30±5</td> </tr> <tr> <td>0.5 &lt; <math>\phi d</math> ≤ 0.8</td> <td>10</td> </tr> <tr> <td>0.8 &lt; <math>\phi d</math> ≤ 1.2</td> <td>25</td> </tr> </table> FBA : A bead shall be fixed and static loaded 20±1N(2.0±0.1 kgf) in axial direction of lead wire in 10±1 seconds. FL05R□ : Fix the component in the direction to draw terminal, and gradually apply the tensile force of 4.9 N.	force(N)	duration(S)	25	5	Nominal wire diameter tensile $\phi d$ (mm)	force (N)	duration(S)	0.3 < $\phi d$ ≤ 0.5	5	30±5	0.5 < $\phi d$ ≤ 0.8	10	0.8 < $\phi d$ ≤ 1.2	25							
force(N)	duration(S)																													
25	5																													
Nominal wire diameter tensile $\phi d$ (mm)	force (N)	duration(S)																												
0.3 < $\phi d$ ≤ 0.5	5	30±5																												
0.5 < $\phi d$ ≤ 0.8	10																													
0.8 < $\phi d$ ≤ 1.2	25																													
11. Over current				There shall be no scorch or short of wire.					LHL□□□ : Measuring current : Rated current×2 Duration : 5min. Number of measuring : one time																					
12. Terminal strength : bending	No abnormality such as cut lead, or looseness.								LA : Suspend a mass at the end the terminal, incline the body though angel of 90 and return it to initial position. This operation is done over a period of 2-3 sec. Then second bend in the opposite direction shall be made. Number of bends : Two times. <table border="1"> <tr> <th>Nominal wire diameter tensile <math>\phi d</math>(mm)</th> <th>Bending force (N)</th> <th>Mass reference weight (kg)</th> </tr> <tr> <td>0.3 &lt; <math>\phi d</math> ≤ 0.5</td> <td>2.5</td> <td>0.25</td> </tr> <tr> <td>0.5 &lt; <math>\phi d</math> ≤ 0.8</td> <td>5</td> <td>0.50</td> </tr> </table> LH · FB · LAV : Suspend a mass at the end the terminal, incline the body though angel of 90 and return it to initial position. This operation is done over a period of 2-3 sec. Then second bend in the opposite direction shall be made. Number of bends : Two times. <table border="1"> <tr> <th>Nominal wire diameter tensile <math>\phi d</math>(mm)</th> <th>Bending force (N)</th> <th>Mass reference weight (kg)</th> </tr> <tr> <td>0.3 &lt; <math>\phi d</math> ≤ 0.5</td> <td>2.5</td> <td>0.25</td> </tr> <tr> <td>0.5 &lt; <math>\phi d</math> ≤ 0.8</td> <td>5</td> <td>0.5</td> </tr> <tr> <td>0.8 &lt; <math>\phi d</math> ≤ 1.2</td> <td>10</td> <td>1.0</td> </tr> </table>	Nominal wire diameter tensile $\phi d$ (mm)	Bending force (N)	Mass reference weight (kg)	0.3 < $\phi d$ ≤ 0.5	2.5	0.25	0.5 < $\phi d$ ≤ 0.8	5	0.50	Nominal wire diameter tensile $\phi d$ (mm)	Bending force (N)	Mass reference weight (kg)	0.3 < $\phi d$ ≤ 0.5	2.5	0.25	0.5 < $\phi d$ ≤ 0.8	5	0.5	0.8 < $\phi d$ ≤ 1.2	10	1.0
Nominal wire diameter tensile $\phi d$ (mm)	Bending force (N)	Mass reference weight (kg)																												
0.3 < $\phi d$ ≤ 0.5	2.5	0.25																												
0.5 < $\phi d$ ≤ 0.8	5	0.50																												
Nominal wire diameter tensile $\phi d$ (mm)	Bending force (N)	Mass reference weight (kg)																												
0.3 < $\phi d$ ≤ 0.5	2.5	0.25																												
0.5 < $\phi d$ ≤ 0.8	5	0.5																												
0.8 < $\phi d$ ≤ 1.2	10	1.0																												
13. Insulation resistance : between the terminals and body				100M $\Omega$ min.					LHL□□□ : Applied voltage : 500 VDC Duration : 60 sec.																					
14. Insulation resistance : between terminals and core					1M $\Omega$ min. (Other than material code MA)				FBA · FBR : Applied voltage : 100 VDC Duration : 60±5 sec.																					
15. Withstanding : between the terminals and body				No abnormality such as insulation damage					(LHL□□□) According to JIS C5102. 7. 1. 3 (C) Metal global method Applied voltage : 500 VDC Duration : 60 sec.																					

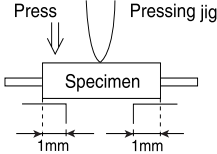
Item	Specified Value								Test Method and Remarks
	LA02 Type/ LA03 Type	LA04 Type	LA05 Type	LHL□□□	FBA/FBR	LAV35	FL05□ Type	FL06BT Type	
16.DC bias characteristic	ΔL/L : Within -10%					ΔL/L : -10% Within			LA · LAV35 : Measure inductance with application of rated current using LCR meter to compare it with the initial value.
17.Body strength	No abnormality as damage.				No significant damage such as cracks on body.	No abnormality as damage.			LA02 · LAV35 : Applied force : 30N Duration : 10 sec. Speed : Shall attain to specified force in 2 sec.  LA03 · LA04 · LA05 : Applied force : 50N Duration : 10 sec. Speed : Shall attain to specified force in 2 sec.  FB : Applied force : 50±3N Duration : 30±1 sec.  
18.Resistance to vibration	ΔL/L : Within±5% Q : 30min.	ΔL/L : Within±5% ΔQ/Q : Within±10%	ΔL/L : Within±5% Q : 15min.	Appearance : No abnormality ΔL/L : Within±5% Q change : Within±30% (LHLP : only ΔL/L)	Appearance : No abnormality Impedance change : Within±20%	ΔL/L : Within±5% Q : 30min.			LA : According to JIS C5102 8. 2 Vibration type : A Directions : 2 hrs each in X, Y and Z directions total : 6hrs. Frequency range : 10 to 55 to 10Hz(1min.) Amplitude : 1.5mm Mounting method : Soldering onto printed board. Recovery : At least 1hr of recovery under the standard condition after the test, followed by the measurement within 2hrs.  LHL□□□ · FB · LAV : According to JIS C0040 Vibration type : A Directions : 2 hrs each in X, Y and Z directions total : 6hrs. Frequency range : 10 to 55 to 10Hz(1min.) Amplitude : 1.5mm (But don't exceed acceleration 196m/s (two power) Mounting method : Soldering onto printed board.

Item	Specified Value								Test Method and Remarks
	LA02 Type/ LA03 Type	LA04 Type	LA05 Type	LHL□□□	FBA/FBR	LAV35	FL05□ Type	FL06BT Type	
19. Resistance to shock	No significant abnormality in appearance					No significant abnormality in appearance			LA・LAV35 : Drop test Impact material : concrete or vinyl tile Height : 1m Total number of drops : 10 times
20. Solderability	At least 75% of terminal electrode is covered by new solder.			At least 75% of lead cir c u , ference is covered by new solder.	At least 90% of lead cir c u , ference is covered by new solder.	At least 75% of lead cir c u , ference is covered by new solder.			LA : Solder temperature : 230±5°C Duration : 2±0.5 sec.  LHL□□□ : Solder temperature : 235±5°C Duration : 2±0.5 sec. Immersion depth : Up to 1.5mm from bottom of kinked part. [LHL06, LHLC06, LHLZ06] : Up to 1.5mm from bottom of case. [LHL08, LHL10, LHL13, LHL16]  FB : Solder temperature : 230±5°C Duration : 3±1 sec. Immersion depth : Up to 1.5mm from terminal root.  LAV35 : Solder temperature : 230±5°C Duration : 2±0.5 sec.  FL05R□ : Solder temperature : 230±5°C Duration : 2±0.5 sec. Immersion depth : Up to 2~2.5mm from terminal root.  FL06BT : Solder temperature : 230±5°C Duration : 3±1 sec. Immersion depth : Up to 0.5~1.0mm from terminal root.

Item	Specified Value								Test Method and Remarks
	LA02 Type/ LA03 Type	LA04 Type	LA05 Type	LHL□□□	FBA/FBR	LAV35	FL05□ Type	FL06BT Type	
21. Resisistance to soldering heat	No significant abnormality in appearance		<p>△L/L : Within ±5% Q : 15min.</p>	<p>No significant abnormality in appearance Inductance change : Within±5% Q change : Within±30% (LHLP : only △L/L)</p>	<p>No significant abnormality in appearance Impedance change : Within±20%</p>	<p>△L/L : Within±5% Q : 30min.</p>	Refer to individual specification	<p>No significant abnormality in appearance Impedance change : Within±20%</p>	<p>LA : Solder temperature : 260±5°C(LA02) 270±5°C(LA03 · LA04 · LA05) Duration : 5±0.5 sec. One time Immersed conditions : Inserted into substrate with t = 1.6mm Recovery : At least 1hr of recovery under the standard condition after the test, followed by the measurement within 2hrs.</p> <p>LHL□□□ : Solder bath method Solder temperature : 260±5°C Duration : 10±1 sec. : Up to 1.5mm from bottom of kinked part. [LHL06, LHLC06, LHLZ06] : Up to 1.5mm from bottom of case. [LHL08, LHL10, LHL13, LHL16, LHLP□□] Manual soldering Solder temperature : 350±10°C(At the tip of soldering iron) Duration : 5±1 sec. : Up to 1.5mm from bottom of kinked part. [LHL06, LHLC06, LHLZ06] : Up to 1.5mm from bottom of case. [LHL08, LHL10, LHL13, LHL16, LHLP□□] Caution : No excessive pressing shall be applied to terminald Recovery : 4 to 24hrs of recovery under the standard condition after the tset.</p> <p>FB : Solder bath method Condition 1 Solder temperature : 260±5°C Duration : 10±1 sec. Immersion depth : Up to 1.5mm from terminal root. Condition 2 Solder temperature : 350±5°C Duration : 3±1 sec. Immersion depth : Up to 1.5mm from terminal root. Recovery : 3hrs of recovery under the standard condition after the test.</p> <p>LAV35 : Solder temperature : 260±5°C Duration : 5±0.5 sec. Immersion depth : Up to 2.0 to 2.5mm from botoom of kinked part. Recovery : 4 to 24hrs of recovery under the standard condition after the tset.</p> <p>FL : Solder condition : 260±5°C 10±1 sec. Immersion depth : Up to 0.5 to 1.0mm from terminal root. Recovery : 3hrs of recovery under the standard condition after the test.</p>

Item	Specified Value								Test Method and Remarks																																																												
	LA02 Type/ LA03 Type	LA04 Type	LA05 Type	LHL□□□	FBA/FBR	LAV35	FL05□ Type	FL06BT Type																																																													
22. Resisittance to solvent	Pleasa avoid the ultrasonic cleaning of this product.				No significant abnormality in appearance Impedance change : Within±20%	Please avoid the ultrasonic cleaning of this product.			FB : Solvent temperature : 20~25°C Duration : 30±5 sec. Solvent type : Acetone, trichloroethylene Recovery : 3hrs of recovery under the standard condition after the test.																																																												
23. Thermal shock	ΔL/L : Within±10% Q : 30min.	ΔL/L : Within±10% ΔQ/Q : Within±30%	ΔL/L : Within±10% Q : 15min.	Appearance : No abnormality Inductance change : Within±10% Q change : Within±30% (LHLP : only ΔL/L)	Appearance : No abnormality Impedance change : Within±20%	ΔL/L : Within±10% Q : 20min.	Refer to individual specification	Appearance : No abnormality Impedance change : Within±20%	LA : Conditions for 1 cycle <table border="1"> <thead> <tr> <th>Step</th> <th>Temperature(°C)</th> <th>Duration(min)</th> </tr> </thead> <tbody> <tr> <td>1</td> <td>-25<sup>+0</sup><sub>-3</sub></td> <td>30±3</td> </tr> <tr> <td>2</td> <td>Room temperature</td> <td>Within 3</td> </tr> <tr> <td>3</td> <td>+85<sup>+2</sup><sub>-0</sub></td> <td>30±3</td> </tr> <tr> <td>4</td> <td>Room temperature</td> <td>Within 3</td> </tr> </tbody> </table> Number of cycles : 5 cycles Recovery : At least 1hr of recovery under the standard condition after the removal from test chamber, followed by the measurement within 2hrs.  LHL□□□ : Accoding to JIS C0025 Conditions for 1 cycle <table border="1"> <thead> <tr> <th>Step</th> <th>Temperature(°C)</th> <th>Duration(min)</th> </tr> </thead> <tbody> <tr> <td>1</td> <td>Minimum operating temperature<sup>+0</sup><sub>-3</sub></td> <td>30±3</td> </tr> <tr> <td>2</td> <td>Room temperature</td> <td>Within 3</td> </tr> <tr> <td>3</td> <td>Maximum operating temperature<sup>+2</sup><sub>-0</sub></td> <td>30±3</td> </tr> <tr> <td>4</td> <td>Room temperature</td> <td>Within 3</td> </tr> </tbody> </table> Number of cycles : 10 cycles (LHL□□□) : 5 cycles(FBA, FBR) Recovery : 4 to 24hrs of recovery under the standard condition after the removal from the test cfamber. (LHL□□□) : 3hrs of recovery under the standard condition after the removal from the test cfamber.(FBA, FBR)  LAV : Conditions for 1 cycle <table border="1"> <thead> <tr> <th>Step</th> <th>Temperature(°C)</th> <th>Duration(min)</th> </tr> </thead> <tbody> <tr> <td>1</td> <td>Minimum operating temperature<sup>+0</sup><sub>-3</sub></td> <td>30±3</td> </tr> <tr> <td>2</td> <td>Room temperature</td> <td>Within 3</td> </tr> <tr> <td>3</td> <td>Maximum operating temperature<sup>+2</sup><sub>-0</sub></td> <td>30±3</td> </tr> <tr> <td>4</td> <td>Room temperature</td> <td>Within 3</td> </tr> </tbody> </table> Number of cycles : 10 cycles Recovery : At least 1hr of recovery under the standard condition after the removal from test chamber, followed by the measurement within 2hrs.  FL : Accoding to JIS C0025 Conditions for 1 cycle <table border="1"> <thead> <tr> <th>Step</th> <th>Temperature(°C)</th> <th>Duration(min)</th> </tr> </thead> <tbody> <tr> <td>1</td> <td>-25<sup>+0</sup><sub>-3</sub></td> <td>30±3</td> </tr> <tr> <td>2</td> <td>Room temperature</td> <td>Within 3</td> </tr> <tr> <td>3</td> <td>+85<sup>+2</sup><sub>-0</sub></td> <td>30±3</td> </tr> <tr> <td>4</td> <td>Room temperature</td> <td>Within 3</td> </tr> </tbody> </table> Number of cycles : 10 cycles Recovery : 1 to 2hrs of recovery under the standard condition after the removal from the test cfamber.	Step	Temperature(°C)	Duration(min)	1	-25 <sup>+0</sup> <sub>-3</sub>	30±3	2	Room temperature	Within 3	3	+85 <sup>+2</sup> <sub>-0</sub>	30±3	4	Room temperature	Within 3	Step	Temperature(°C)	Duration(min)	1	Minimum operating temperature <sup>+0</sup> <sub>-3</sub>	30±3	2	Room temperature	Within 3	3	Maximum operating temperature <sup>+2</sup> <sub>-0</sub>	30±3	4	Room temperature	Within 3	Step	Temperature(°C)	Duration(min)	1	Minimum operating temperature <sup>+0</sup> <sub>-3</sub>	30±3	2	Room temperature	Within 3	3	Maximum operating temperature <sup>+2</sup> <sub>-0</sub>	30±3	4	Room temperature	Within 3	Step	Temperature(°C)	Duration(min)	1	-25 <sup>+0</sup> <sub>-3</sub>	30±3	2	Room temperature	Within 3	3	+85 <sup>+2</sup> <sub>-0</sub>	30±3	4	Room temperature	Within 3
Step	Temperature(°C)	Duration(min)																																																																			
1	-25 <sup>+0</sup> <sub>-3</sub>	30±3																																																																			
2	Room temperature	Within 3																																																																			
3	+85 <sup>+2</sup> <sub>-0</sub>	30±3																																																																			
4	Room temperature	Within 3																																																																			
Step	Temperature(°C)	Duration(min)																																																																			
1	Minimum operating temperature <sup>+0</sup> <sub>-3</sub>	30±3																																																																			
2	Room temperature	Within 3																																																																			
3	Maximum operating temperature <sup>+2</sup> <sub>-0</sub>	30±3																																																																			
4	Room temperature	Within 3																																																																			
Step	Temperature(°C)	Duration(min)																																																																			
1	Minimum operating temperature <sup>+0</sup> <sub>-3</sub>	30±3																																																																			
2	Room temperature	Within 3																																																																			
3	Maximum operating temperature <sup>+2</sup> <sub>-0</sub>	30±3																																																																			
4	Room temperature	Within 3																																																																			
Step	Temperature(°C)	Duration(min)																																																																			
1	-25 <sup>+0</sup> <sub>-3</sub>	30±3																																																																			
2	Room temperature	Within 3																																																																			
3	+85 <sup>+2</sup> <sub>-0</sub>	30±3																																																																			
4	Room temperature	Within 3																																																																			

Item	Specified Value								Test Method and Remarks
	LA02 Type/ LA03 Type	LA04 Type	LA05 Type	LHL□□□	FBA/FBR	LAV35	FL05□ Type	FL06BT Type	
24.Damp heat	ΔL/L : Within±10% Q : 30min.	ΔL/L : Within±10% ΔQ/Q : Within±30%	ΔL/L : Within±10% Q : 15min.		Appearance : No abnormality Impedance change : Within±20%	ΔL/L : Within±10% Q : 20min.			LA · LAV35 : Temperature : 40±2°C Humidity : 90~95%RH Duration : 1000 hrs Recovery : At least 1hr of recovery under the standard removal from test chamber, followed by the measurement within 2hrs.  FB : Temperature : 60±2°C Humidity : 90~95%RH Duration : 1000 hrs Recovery : 1 to 2hrs of recovery under the standard condition after the removal from the test chamber.
25.Loading under damp heat	ΔL/L : Within±10% Q : 30min.	ΔL/L : Within±10% ΔQ/Q : Within±30%	ΔL/L : Within±10% Q : 15min.	Appearance : No abnormality Inductance change : Within±10% Q change : Within±30% (LHLP : only ΔL/L)		ΔL/L : Within±10% Q : 20min.	Refer to individual specification	Appearance : No abnormality Impedance change : Within±20%	LA · LAV35 : Temperature : 40±2°C Humidity : 90~95%RH Duration : 1000 hrs Applied current : Rated current Recovery : At least 1hr of recovery under the standard removal from test chamber, followed by the measurement within 2hrs.  LHL□□□ : Temperature : 40±2°C Humidity : 90~95%RH Duration : 1000±24 hrs Applied current : Rated current Recovery : 1 to 2hrs of recovery under the standard condition after the removal from the test chamber.  FL : Temperature : 60±3°C Humidity : 90~95%RH Duration : 500 (+12, -0)hrs Applied current : Rated current Recovery : 1 to 2hrs of recovery under the standard condition after the removal from the test chamber.
26.Loading at high temperature	ΔL/L : Within±10% Q : 30min.	ΔL/L : Within±10% ΔQ/Q : Within±30%	ΔL/L : Within±10% Q : 15min.			ΔL/L : Within±10% Q : 20min.			LA · LAV35 : Temperature : 85±2°C Duration : 1000 hrs Applied current : Rated current Recovery : At least 1hr of recovery under the standard removal from test chamber, followed by the measurement within 2hrs.



Item	Specified Value								Test Method and Remarks
	LA02 Type/ LA03 Type	LA04 Type	LA05 Type	LHL□□□	FBA/FBR	LAV35	FL05□ Type	FL06BT Type	
27.Low temperature life test	<p>△L/L : Within±10% Q : 30min.</p>	<p>△L/L : Within±10% △Q/Q : Within±30%</p>	<p>△L/L : Within±10% Q : 15min.</p>	<p>Appearance : No abnormality Inductance change : Within±10% Q change : Within±30% (LHLP : only △L/L)</p>		<p>△L/L : Within±10% Q : 20min.</p>	Refer to individual specification	<p>Appearance : No abnormality Impedance change : Within±20%</p>	<p>LA : Temperature : -25±2°C Duration : 1000 hrs Recovery : At least 1hr of recovery under the standard removal from test chamber, followed by the measurement within 2hrs.</p> <p>LHL□□□ : Temperature : -40±3°C Duration : 1000±24 hrs Recovery : 1 to 2hrs of recovery under the standard condition after the removal from the test chamber.</p> <p>LAV35 : Temperature : -40±3°C Duration : 1000 hrs Recovery : At least 1hr of recovery under the standard removal from test chamber, followed by the measurement within 2hrs.</p> <p>FL : Temperature : -40±3°C Duration : 500(+12, -0)hrs Recovery : 1 to 2hrs of recovery under the standard condition after the removal from the test chamber.</p>
28.High temperature life test				<p>Appearance : No abnormality Inductance change : Within±10% Q change : Within±30%</p>			Refer to individual specification	<p>Appearance : No abnormality Impedance change : Within±20%</p>	<p>LHL□□□ : Temperature : 105±3°C Duration : 1000±24 hrs Recovery : 1 to 2hrs of recovery under the standard condition after the removal from the test chamber.</p> <p>FL : Temperature : 85±3°C Duration : 500(+12, -0)hrs Recovery : 1 to 2hrs of recovery under the standard condition after the removal from the test chamber.</p>

## PRECAUTIONS

LA Type, LH Type, FB Type, FL Type

Stages	Precautions	Technical considerations
1.Circuit Design	<p>Operating environment,</p> <p>1.The products described in this specification are intended for use in general electronic equipment,(office supply equipment, telecommunications systems, measuring equipment, and household equipment). They are not intended for use in mission-critical equipment or systems requiring special quality and high reliability (traffic systems, safety equipment, aerospace systems, nuclear control systems and medical equipment including life-support systems,) where product failure might result in loss of life, injury or damage. For such uses, contact TAIYO YUDEN Sales Department in advance.</p>	
2.PCB Design	<p>Design</p> <p>1.Please design insertion pitches of a base in the pitches that fitted a terminal interval.</p>	<p>1.When Inductors are mounted onto a PC board, hole dimensions on the board should match the lead pitch of the component, if not, it will cause breakage of the terminals or cracking of terminal roots covered with resin as excess stress travels through the terminal legs.</p>
3.Considerations for automatic placement	<p>Adjustment of mounting machine</p> <p>1.Excessive impact load should not be imposed on the products when mounting onto the PC boards.</p> <p>2.Mounting and soldering conditions should be checked beforehand.</p>	<p>1. When installing products, care should be taken not to apply distortion stress as it may deform the products.</p>
4.Soldering	<p>Wave soldering</p> <p>1.Please refer to the specifications in the catalog for a wave soldering.</p> <p>2.Do not immerse the entire Inductors in the flux during the soldering operation.</p> <p>Lead free soldering</p> <p>1.When using products with lead free soldering, we request to use them after confirming of adhesion, temperature of resistance to soldering heat, soldering etc sufficiently.</p> <p>Recommended conditions for using a soldering iron: Put the soldering iron on the land-pattern. Soldering iron's temperature - Below 350 °C Duration - 3 seconds or less The soldering iron should not directly touch the inductor.</p>	<p>1.If products are used beyond the range of the recommended conditions, heat stresses may deform the products, and consequently degrade the reliability of the products.</p>
5.Cleaning	<p>Cleaning conditions</p> <p>1.LA type, LH type Please do not do cleaning by a supersonic wave.</p>	<p>LA type, LH type</p> <p>1.If washing by supersonic waves, supersonic waves may deform products.</p>
6.Handling	<p>Handling</p> <p>1.Keep the inductors away from all magnets and magnetic objects.</p> <p>Mechanical considerations</p> <p>1.Please do not give the inductors any excessive mechanical shocks.</p> <p>2.LH type If inductors are dropped onto the floor or a hard surface they should not be used.</p> <p>Packing</p> <p>1.Please do not give the inductors any excessive mechanical shocks.</p> <p>In loading, please pay attention to handling indication mentioned in a packing box (a loading direction / number of maximum loading / fragile item).</p>	<p>1. There is a case that a characteristic varies with magnetic influence.</p> <p>1. There is a case to be damaged by a mechanical shock.</p> <p>2.LH type There is a case to be broken by a fall.</p> <p>1. There is a case that a lead route turns at by a fall or an excessive shock.</p>
7.Storage conditions	<p>Storage</p> <p>Storage</p> <p>1.To maintain the solderability of terminal electrodes and to keep the packing material in good condition, temperature and humidity in the storage area should be controlled..</p> <p>· Recommended conditions</p> <p>Ambient temperature           0~40°C</p> <p>Humidity                       Below 70 % RH</p> <p>The ambient temperature must be kept below 30°C. Even under ideal storage conditions, solderability of products electrodes may decrease as time passes. For this reason, inductors should be used within one year from the time of delivery.</p> <p>In case of storage over 6 months, solderability shall be checked before actual usage.</p>	<p>1. Under a high temperature and humidity environment, problems such as reduced solderability caused by oxidation of terminal electrodes and deterioration of taping/package materials may take place.</p>